

Case Study

ConDex Condensing Economizer Delivers Energy, Financial and Environmental Benefits For Nestle Inc.

The Nestle Canada, Chesterville, Ontario plant produces confectionary, coffee and beverage products primarily. As a conscientious corporate citizen, Nestle Canada is always looking for ways to conserve energy, reduce emissions and lower operating costs. In pursuit of their energy efficiency goals, Nestlé Canada contacted Combustion & Energy Systems to investigate potential energy recovery solutions.



The power plant consists of a package boiler producing 60,000 lbs/hr of steam and a 40,000-lb/hr boiler burning spent coffee grounds. The energy investigation conducted by Combustion & Energy Systems revealed the availability of reusable heat energy being exhausted as well as the existence of two heat sinks that were consuming 100% purchased energy.

Because the spent coffee grounds are dried before they are burned, the dryer exhaust represented one of the best sources of recoverable heat. The challenge resided in the effective and efficient extraction of energy.

Stack testing was done to determine the properties for the design details. The tests revealed that the dryer exhaust gas contained 59.4% water by volume with 0.066 lbs/hr particulate. Based on this data, a ConDex system was designed to heat boiler make up water from 60° F to 170° F. The exhaust gas temperature is lowered from 190° F to 127° F and the heat transferred is 1,890,809 Btu/hr. The system condenses 1,903 lbs/hr of water from the exhaust gas. In addition to the ConDex system for dryer exhaust heat recovery, the project also included the installation of a feedwater economizer, which utilized the waste heat from the package boiler.

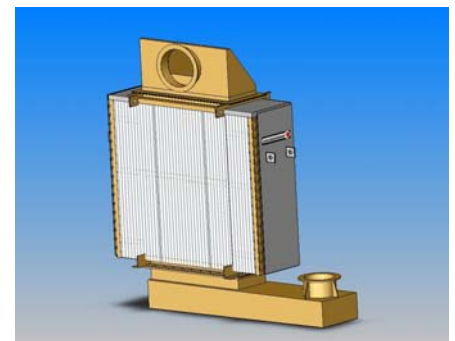

The complete energy recovery solution provided by the ConDex System results in yearly fuel expenditure savings of \$188,600.00. The installed cost payback for the system was less than 11 months. The reduction in fuel being burned also reduces the plant emission of CO₂ and NO_x accordingly. ConDex energy recovery systems can recover both latent and sensible heat from boilers, dryers, ovens, furnaces or any hot process exhaust gas.